

Research and development on geothermal energy in Europe

J.D.GARNISH



Garnish, J.D. 1991. Research and development on geothermal energy in Europe. *Proceedings of the Ussher Society*, 7, 309-315.

J.D. Garnish, DGXII, Commission of the European Communities, Brussels.

Introduction

This is an overview of the European geothermal scene, of which Hot Dry Rock (HDR) research is becoming an increasingly important part. Europe would not be as involved in HDR today as it actually is had it not been for the major project operated by Camborne School of Mines since the mid-1970s.

Geothermal world status

The focus of this paper is Europe, but to set the European developments in context I would like first to bring you up to date on the world scene. Let me remind you that, although our local interest here in the south-west is Hot Dry Rock, this is still a research technology and all commercial development of geothermal energy so far has relied on the presence of naturally occurring steam and hot water. Resources are categorised somewhat arbitrarily as high-enthalpy - temperatures above about 150°C - and low-enthalpy - generally below 100°C.

The former, though restricted to zones of recent volcanic and tectonic activity, are the more important commercially and, with few exceptions, are used for electricity generation. Although Italy began as early as 1904, the Tuscan installations were essentially destroyed during WWII and everyone began again virtually from scratch in the 1950s. Progress was steady but unspectacular until the oil embargoes of the 1970s, when things really took off with growth rates exceeding 14% p.a. (Fig. 1). There has been a slowdown over the past few years because of adverse economic conditions and low oil prices, but growth is still running at better than 8% p.a. There is currently about 6000MWe on-line worldwide and this should rise to well over 10,000MWe by the end of the decade. The major producing countries are illustrated in Fig.2.

Although the development of new reserves is determined by local economic conditions, it is worth pointing out that the best high enthalpy resources can support generation at costs comparable with those from hydropower; in Central America, for example, geothermal electricity is claimed to cost as little as 25% of the cost from oil-fired plant.

More widespread, though generally more marginal from an economic point of view, is the direct use of lower temperature fluids for space heating, horticulture, etc. Although these developments are usually listed, by analogy with the power producers, in terms of "installed thermal megawatts", this can give a very misleading view because of large differences from one country to another in load factor, rejection temperature, etc. I prefer to think in terms of useful energy supplied; on this basis, direct applications exploit about 3 million tonnes of oil equivalent per year (mtoe/y). There are about 60 countries in the business, but the bulk of the development has taken place in 9 or 10 of them (Fig.3).

European geothermal status

To focus on the European scene, high-enthalpy resources - being controlled by tectonic activity and/or recent volcanism - occur

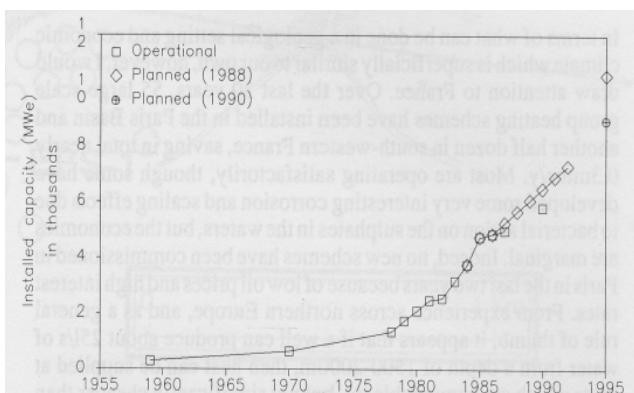

Figure 1. Worldwide installed capacity for electrical generation from geothermal resources (data from DiPippo 1988; Hutter 1990).

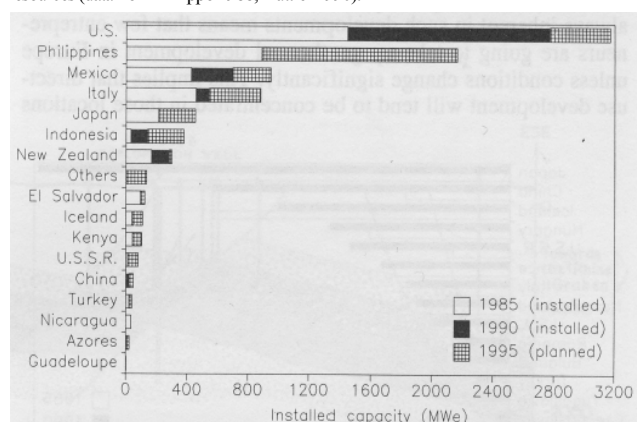

Figure 2. The development of geothermal power generation in the major user countries (data from Hutter 1990).

only around the Mediterranean region, together with the Azores and the Canaries (and, stretching the definition of Europe, in Iceland).

The only major installations occur in Tuscany, where there is about 500MWe of installed capacity. Many of these plants are more than 30 years old, however, and ENEL have recently embarked on a major redevelopment plan which will both replace the old plant with more efficient, modern designs and almost double the existing installed capacity to 885MWe by 1995. Turkey (not yet a Member State of the Community) has a 20MWe installation and plans to double that by 1995, Portugal has a 3MWe pilot plant in the Azores and is drilling for a planned 20MWe unit, and Greece has recently shut down its 2MWe pilot plant on Milos. The reasons for this last shut-down are complex and span both technical and institutional problems. The potential is high in Greece, particularly in the islands, and I hope that such problems will be resolved in the

not-too-distant future. Outside these countries, however, there seems little prospect of practical power generation on a useful scale from conventional geothermal resources.

The technical prospects for direct use of low enthalpy resources are rather better. Looking again at Fig.3, we see that many of the European countries appear to a greater or lesser extent. Top of the list comes Hungary, where the waters of the Pannonian Basin have been exploited for more than 50 years for space heating, horticulture and bathing. Unfortunately, the virtually uncontrolled exploitation of more than 1000 wells during that period has resulted in significant drawdown. All the wells used to be artesian; most now require downhole pumps to sustain the flow. It seems probable that many of these schemes will come in for re-appraisal under the new economic regime. Several of the other eastern European countries have significant direct use applications, though it has been difficult in the past to obtain much reliable information on performance and economics.

In terms of what can be done in a geological setting and economic climate which is superficially similar to our own, however, I would draw attention to France. Over the last 30 years, 55 large-scale group heating schemes have been installed in the Paris Basin and another half dozen in south-western France, saving in total nearly 0.3mtoe/y. Most are operating satisfactorily, though some have developed some very interesting corrosion and scaling effects due to bacterial action on the sulphates in the waters, but the economics are marginal. Indeed, no new schemes have been commissioned in Paris in the last two years because of low oil prices and high interest rates. From experience across northern Europe, and as a general rule of thumb, it appears that if a well can produce about 251/s of water from a depth of 1500-2000m, then heat can be supplied at costs which are comparable to - but not significantly cheaper than - those from conventional fossil fuel sources. The absence of a marked cost advantage coupled with the geological risks which are always inherent in such developments means that few entrepreneurs are going to take up geothermal development in Europe unless conditions change significantly. This implies that direct use development will tend to be concentrated in those locations

where special considerations apply - either better than average geological conditions or environmental restrictions on fossil fuel use, for example.

Further detail on direct use applications can be found in a recent publication by Harrison *et al.* (1990), which includes technical and economic case studies of more than 50 direct use schemes in France, Iceland and the USA.

The role of the European Commission

In case that sounds too gloomy, it is worth pointing out that direct use applications are showing a respectable rate of growth. More significantly, the potential for their development in Europe as and when needed is much higher than it was 20 years ago. In France and Italy the European Community possesses two of the world leaders in geothermal technology, but little had been done elsewhere in the Community prior to the 1973 oil embargo. The Commission's role, since it entered the field of geothermal R&D in 1975, can be summarised as "to make available to each Member State the option of exploiting its indigenous geothermal resources". In the case of most Member States, this meant assisting them to explore and catalogue their resources, and then to develop demonstration plants where appropriate. In fact, every Member State except Luxembourg now has at least one geothermal demonstration plant in operation, and most have several.

Inherent in the Commission's task was assistance where appropriate with technology transfer from more geothermally -advanced countries. Thus, in the early years, the Commission put a lot of effort into helping to develop national programmes of exploration and resource assessment. This included a substantial amount of exploration drilling but also, and perhaps of greater importance in the long term, it involved bringing together research teams from the different countries to share their experience. If one document can typify this aspect of the Commission's work, it is the publication in 1988 of the "Atlas of Geothermal Resources in the European Community, Austria and Switzerland", containing more than 400 maps and cross sections of different geothermal aquifers, all presented in a standard format to simplify cross-border comparisons (Haenel and Staroste 1988). It is worth noting the inclusion of Austria and Switzerland in the Atlas as an example of the Commission's outward-looking attitude to its work. The EFTA countries are becoming increasingly involved with the Commission's R&D programmes, and discussions are already under way with eastern bloc countries.

The publication of the Resources Atlas really marks the achievement of one of the Commission's objectives in geothermal research, and hence the end of a need for Commission involvement in one aspect of the work - support to individual groups. From here on, we can justify using European funding only on work of generic interest. In the classical geothermal field, such generic problems arise in the handling and use of geothermal fluids, and we are supporting collaborative multi-national studies on corrosion and scaling in geothermal systems and on the handling of high-salinity brines.

Hot Dry Rock

Of even greater potential interest, however, and one of the reasons why this meeting is being held here today, is the so-called Hot Dry Rock research. Briefly, this is research aimed ultimately at extracting useful heat from rock formations which possess insufficient natural permeability to allow extraction of heated natural groundwater at the required rate.

Since the majority of the world's land masses are underlain by more-or-less impermeable crystalline rocks, solution of the HDR problem would open up a huge and widespread resource. Available temperatures would no longer be limited by the depth of a convenient permeable formation, but only by the cost of drilling to the necessary depth. Temperatures suitable for electricity generation should be achievable in areas of quite modest geothermal gradient, and the ability to produce electricity means that sites

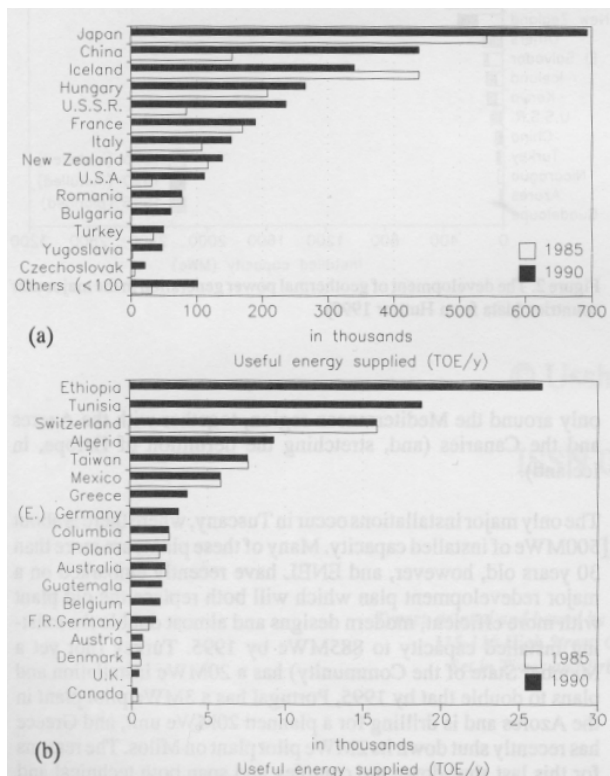

Figure 3. Direct usage of geothermal energy (a) for countries with >100MWt installed (b) for countries with <100MWt installed (data from Freeston 1990)

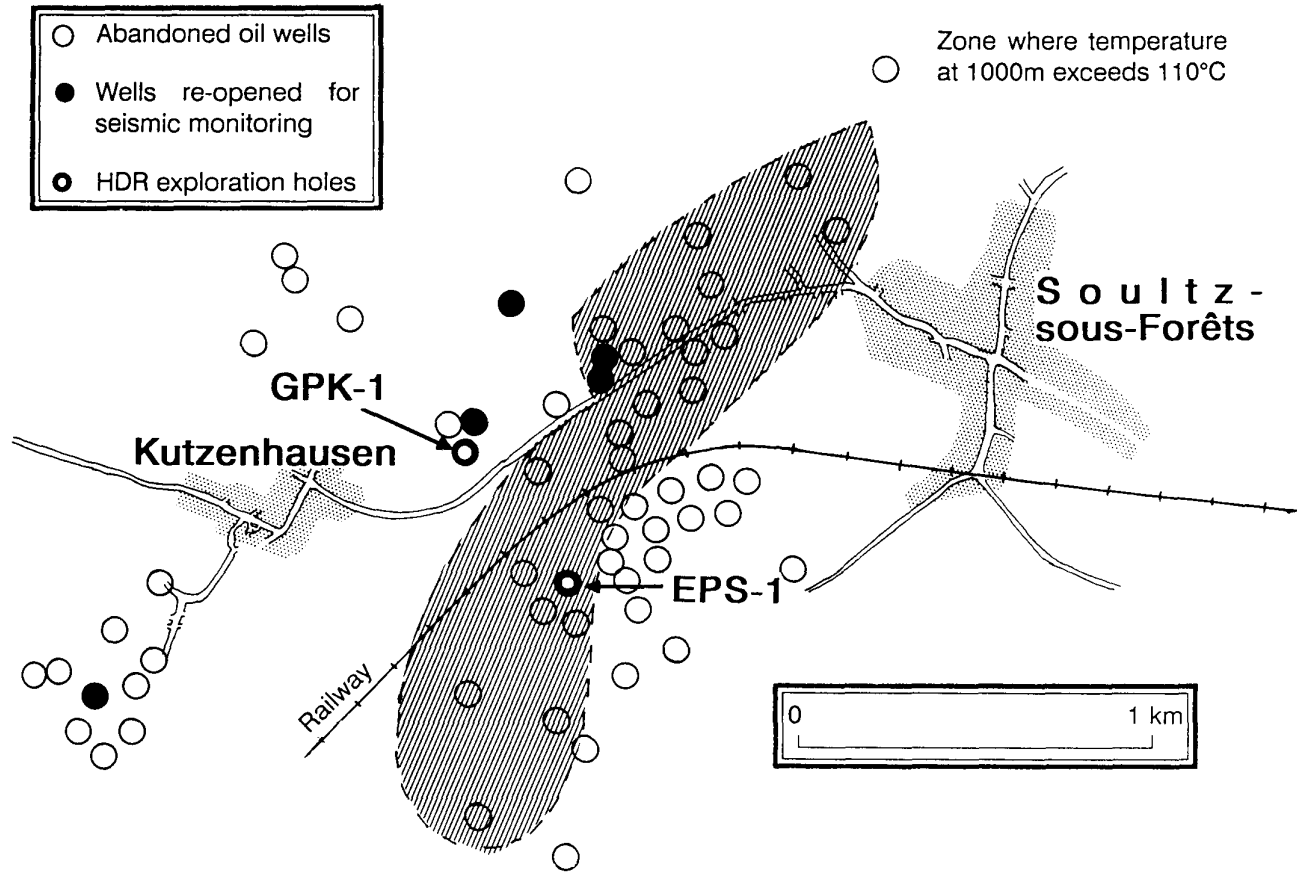

Figure 4. Details of the Soutz site.

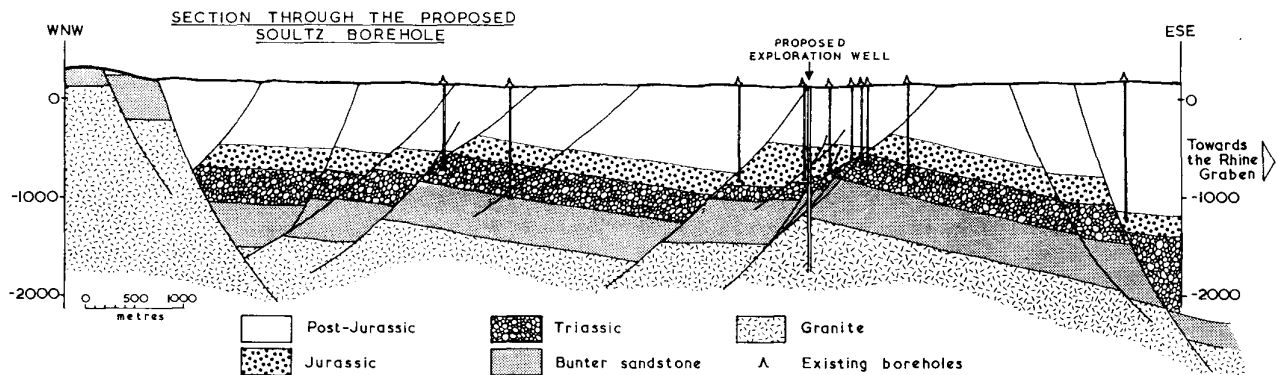

Figure 5. Simplified cross-section of the Rhine Valley through the Soutz site.

could be developed which are much more remote from their markets than would be tolerable for direct heat applications. Even with only 5% recovery, Batchelor (1989) has estimated that the thermal reserves of the European landmass could be 37 000 million tonnes of coal equivalent.

Such a potential justifies a large research effort, which is just as well because the costs of research are also high. Table 1, from Batchelor (1989), shows what has been spent so far. I estimate that the costs of a full-scale pilot project in Europe will be at least a further \$70 million.

Table 1. Expenditure on HDR Research 1970-1989.

			Million US\$
* USA	Primarily Fenton Hill		132
* UK	Primarily Rosemanowes		47
* Japan	NEDO, Tohoku, CRIEPI and NRIPR		27
* France			8
* Germany	Falkenberg, Urach, Fenton Hill		33
(* Includes EC support)			total 247

Several countries have risen to the challenge over the last 20 years. Notable among these efforts, in terms of achievement, have been the US project at Fenton Hill, Los Alamos, and the CSM project

here at Rosemanowes. It is sufficient here to note simply that both these were major field experiments aimed at interlinking deep boreholes in granite by way of fractures. Both (in common with all the smaller scale projects attempted elsewhere) use hydraulic fracturing techniques to induce or stimulate fractures which can act as heat exchangers. The state of the art for all the major projects was presented in a Special Issue of "Geothermics" in 1987.

Much has been learnt in the course of the work, most notably that: (a) all the sites examined show a pervasive natural fracture system at depth;

(b) a proportion of these natural fractures tend to be open already or are readily stimulated by hydraulic pressure, and can support circulation between boreholes spaced several hundred metres apart;

(c) artificial fractures are induced only under unusual conditions, and are effective only for short distances from the borehole;

(d) the stimulation techniques used so far have been only partially successful in reducing the flow resistance of the fracture system; in particular, no project has yet achieved sustainable impedances that are less than 2-3 times those that will be required for commercial operation;

(e) significant long-term circulations have been achieved, but these have shown that the effective heat transfer areas are not yet sufficiently large to give the required lifetimes.

Within Europe, we recognise the potential importance of HDR technology. Of the Community countries, France and Germany have now come together in a collaborative project in the Upper Rhine Valley and Italy, with a view to eventual exploitation of the dry zones of the Tuscany fields, is waiting on the sidelines. From EFTA, both Switzerland and Sweden have small-scale projects of their own and are waiting to join in the European work. The question is - what course should the European work take?

The key questions, such as impedance to flow and effective heat-transfer area, revolve around the properties of the natural fracture systems and their environment. As any reservoir will be constrained by the in-situ fracture and stress conditions, it is felt that the next major step in HDR development must be taken at full depth in order to take account of these conditions. Consequently, we are looking towards the construction of a full depth prototype HDR plant.

The cost of such a development, allowing for the further research which will be needed, will be very significant, with minimum estimates in the range of 50-75 million ECU (1 ECU ~1.3 US\$). Quite clearly, and especially in view of the fact that the rationale for HDR development is based on the supposed general applicability of the technique, it would make no sense for the different European countries each to embark on their own projects; what is needed is a single European prototype in which all the different research teams will be involved. That being the case, the first step will be the choice of site. Unfortunately, our options are severely limited by the paucity of relevant data at the depths of interest. It should be remembered that the Rosemanowes project was designed as a rock mechanics experiment, not as an energy producer, and that it would be necessary to go to significantly greater depth to achieve useful temperatures - perhaps 5-6000m for 175°C+. We know a great deal about Cornwall down to 2600m, thanks to the Rosemanowes work, but extrapolation to 6000m involves many uncertainties. We have some rather limited information to a depth of 3500m at Urach in Germany, a possible site where a working depth of about 4500-5000m would be necessary, and we have good data from 2000m for the Franco-German site in the Upper Rhine Valley at Soultz, just north of Strasbourg. At Soultz, however, a depth of 3500m should be adequate to give the temperatures required for a prototype system and so the current phase of the European programme is aimed at obtaining basic data from that depth.

The work at Soultz makes an interesting comparison with the Rosemanowes project. The site is that of the old Pechelbron

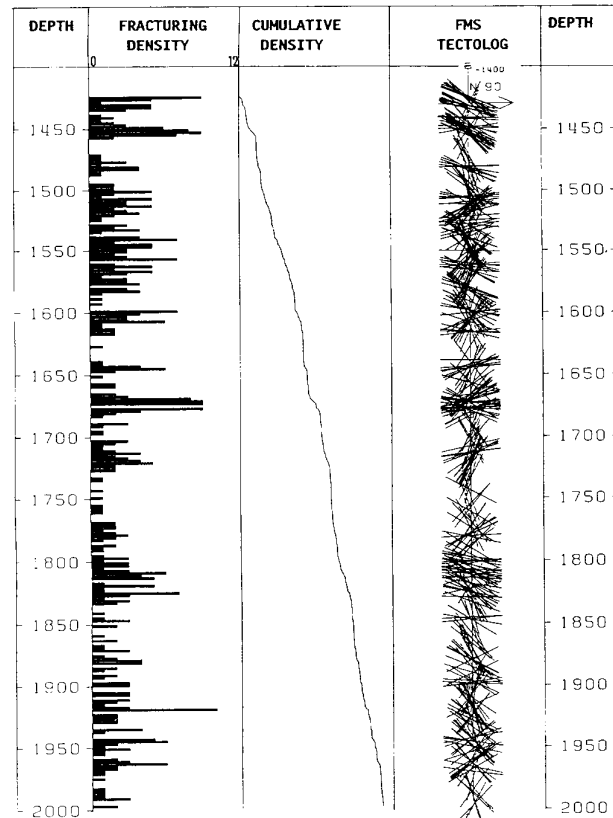
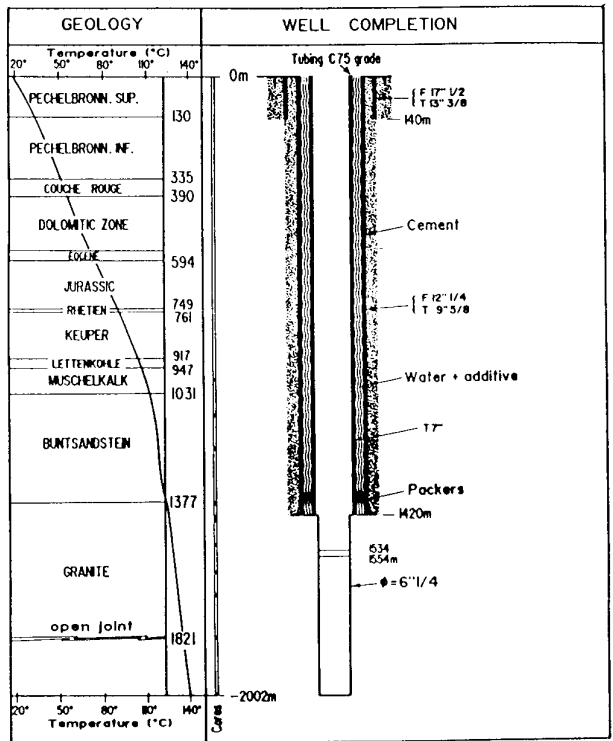

Figure 6. Logging in GPK-1 (Genter 1989; Gerard and Kappelmeyer 1989).

oilfield, which was abandoned in the late 1950s. Consequently, there are some 90 abandoned wells within a few square kilometres, the majority around 1000m deep and stopping just short of the top of the granite basement within the Upper Rhine Valley (Figs. 4 and 5).

Data from the oil drillings had shown that a significant thermal anomaly existed at the site, with temperature gradients in the

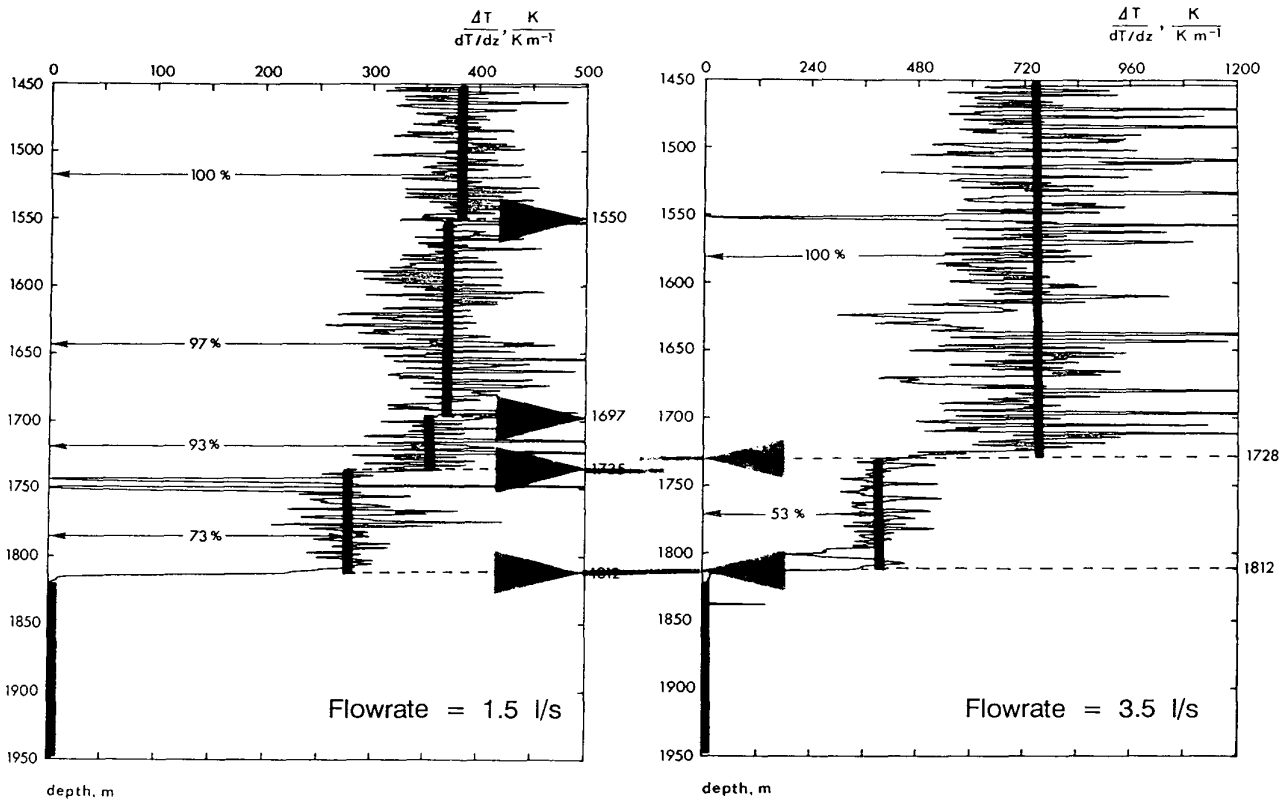

Figure 7. Thermal flowmeter logging during injection in GPK-1 (Schellschmidt and Schultz 1989).

sediments rising as high as $100^{\circ}\text{C km}^{-1}$. Although this localised anomaly is almost certainly due to local fluid convection, the effect is that the top of the granite is as hot as 120°C in some areas, which would reduce significantly the depth necessary to achieve the desired temperature for an HDR system of $175\text{--}200^{\circ}\text{C}$.

The first stage, carried out by French and German teams with support from the Commission, consisted of reopening and deepening several oil holes just into the granite to act as seismic observation wells, and drilling a new well to 2000m. This well, GPK-1 (Fig. 4), penetrated some 600m of granite. It encountered at least one open fracture zone between 1812-1825m from which water flowed to surface at about 11/s; chemical studies suggested that the water had a common origin with that in the overlying sediments and thus was likely to be part of the overall convection system. The temperature gradient in the granite is "normal" at about $30^{\circ}\text{C km}^{-1}$, unlike that in the overburden, so that the bottom hole temperature at 2000m is 140°C . The borehole was logged using both FMS and BHTV, revealing extensive fracturation (Fig. 6).

The in-situ stress field is as expected in a graben system, with the maximum horizontal stress aligned roughly parallel to the graben axis, and the vertical stress being greater than either horizontal component. Application of hydraulic pressure thus results - as might be expected in an active graben system - in shear movement by normal faulting (in contrast to the strike slip seen in Cornwall). Calculations also suggest that the fractures are almost in equilibrium with the hydrostatic pore pressure, so that quite small overpressures can induce failure. This is supported by the observation of axial fracturing in some parts of the GPK-1 well which are almost certainly due to surge pressures during drilling and tripping. Unfortunately, it was possible to measure stresses over only a short section of the granite, and extrapolation to the required 3500m is extremely speculative.

In addition, some limited hydraulic tests were carried out, showing that a small number of fractures were hydraulically active (perhaps

only 2-3% of all the fractures detected by logging). This is illustrated in Fig. 7, taken from Schellschmidt and Schultz (1989), which shows the results of flowmeter logging over a section of GPK-1 during low flow rate injection tests. It can be seen that at flow rates of 1.51/s the flow is absorbed by only four major fractures; at a flow rate of 3.51/s, which required only a slightly higher injection pressure, the acceptance is even more selective. The bulk of the flow still leaves the hole at 1812m, but now almost as much leaves through a fracture at 1728m which was not even detectable at the lower pressure. Interestingly, the other fractures cease to be detectable. Although such behaviour is intuitively difficult to understand, it is interesting to note that similar behaviour was seen in the early experiments in Cornwall. There is some evidence that these hydraulically active fractures in GPK-1 connect to a large storage volume within the granite, though it is a matter of opinion whether this is a large fault or simply the bulk of the natural fracture system. As we had only a single well to this depth, no circulation tests were possible. Details of all this work have been published in a Special Issue of *"Geothermal Science and Technology"*.

Limited though these data were, the results were sufficiently encouraging to prompt further work at the site, which is now under way. This is now a French-German-British collaboration, with the Commission's contribution being to provide a permanent site facility and to pay for the cost of drilling a slim hole to the full 3500m (designated EPS-1, Fig. 4). This will still not permit circulation through the region of interest, but should enable all the other necessary data - notably fracturation and in-situ stress - to be measured directly. This work should be completed late in 1991.

In parallel with this, and as data become available, a "feasibility study" will be carried out on the suitability of the Soultz site as a possible host for the future single European prototype. That study will be carried out in a way that retains compatibility with the similar study already completed for Cornwall. Meanwhile, a German consortium will be performing a feasibility study for Urach. Finally, the three studies will be compared in order to

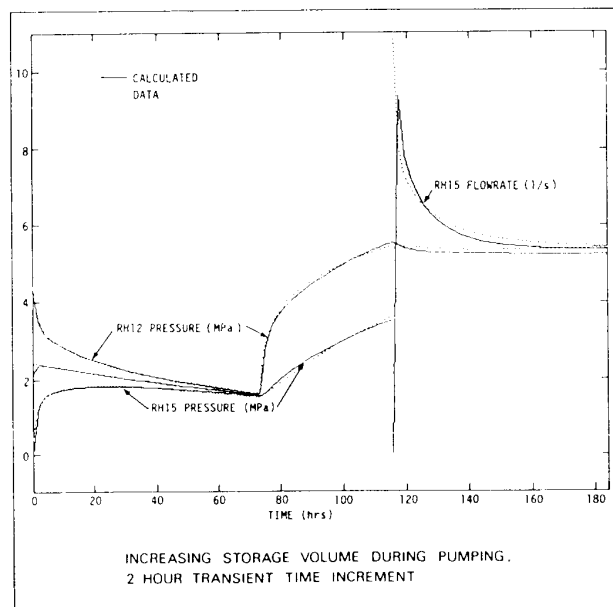
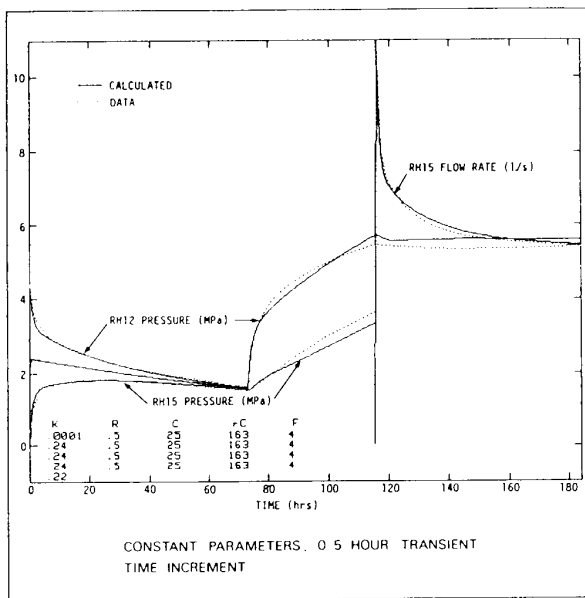
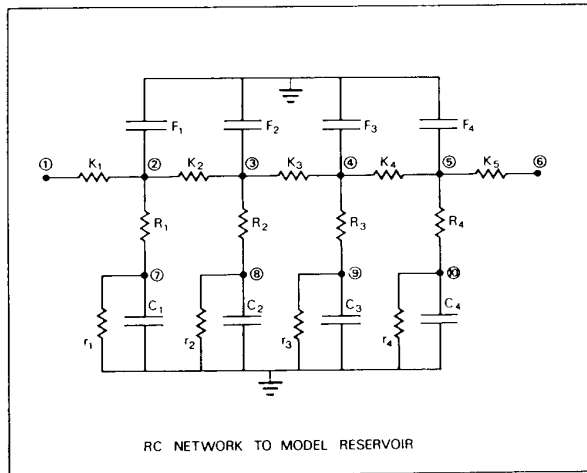

Figure 8. Modelling of injection tests at Rosemanowes using an electrical analogue (Lawton 1986).

choose the final site, ideally by mid- 1992. All three governments are backing this study, and a multi-national industrial consortium has recently been formed to take charge of the prototype development, wherever it might be sited.

It is worth pointing out that, although at first sight Soultz might appear more attractive than Cornwall because of the lower cost of drilling to 3500m rather than 5500-6000m, the difference in costs represents only around 10% of the entire research package and could easily prove to be offset by some other factor. I would emphasise, therefore, that the choice of site is far from a foregone conclusion.

As part of this exercise, we have recently prepared an outline of the work required to achieve a working prototype producing useful energy and demonstrating each of the key parameters on the necessary scale. Even assuming that we need only two boreholes, that we understand what we are doing and that no major problems occur, the work would take until 1998-2000 and, as indicated earlier, cost 50-75 million ECU.

Before we commit ourselves to such costs, however (or, more realistically, before the Member States make available the sort of budget required), we need to ask what are our chances of success. Of the remaining problems, two seem to me to be crucial. One is the question of water losses, and the second that of impedance.

Both Fenton Hill (Los Alamos) and Rosemanowes have experienced large and continuing water losses, averaging 20% or more of the injected flow. Water losses represent an economic penalty, both in the cost of the water itself and, more significantly, in the pumping power used to circulate the lost water. Economic modelling suggests that losses must be kept below 10% for commercial operation.

These losses have several causes:

- (a) Diffusion in the rock matrix forming the wall of the heat exchange fractures; though significant in the first few weeks of circulation, these should diminish exponentially with time.
- (b) Losses into the natural fracture system because a system of only one well pair results in inefficient drainage. These could be reduced - at a cost - by multiple production wells.
- (c) Losses due to uncontrollable growth of the fracture system when the pressure at some point in the reservoir exceeds that necessary to trigger further shear movement. Since that critical pressure sets an upper limit on the [flow rate x impedance] product, and economic operation depends on maximising the flow rate, it follows that we must minimise the impedance of the reservoir.

Impedance thus becomes, in my view, the critical parameter. No-one has yet reliably achieved impedance values better than a factor of 2-3 greater than we think will be needed. Indeed, for a long time no-one really knew what determined the impedance of the overall system and attempts to reduce it met with only limited success. In the early days, it was assumed that the critical parameter was fracture aperture, especially close to the borehole where stress concentrations and fluid velocities are high. Experiments with proppants and high back-pressures, however, provided only a partial solution, and it now appears that the observed overall impedance is in fact distributed throughout the reservoir. The earliest evidence for this came from some work by one of the Los Alamos team while he was working at Rosemanowes (Lawton 1986).

He developed an electrical analogue model in order to match the observed response of the reservoir to variations in inlet pressure. For a series of low-pressure tests he was able to obtain quite a good correlation from a model with impedances distributed almost uniformly throughout the system (Fig. 8).

Further insights are given by recent modelling by a number of groups using the stochastic disc method, whereby natural fractures are represented by discs distributed through space with densities,

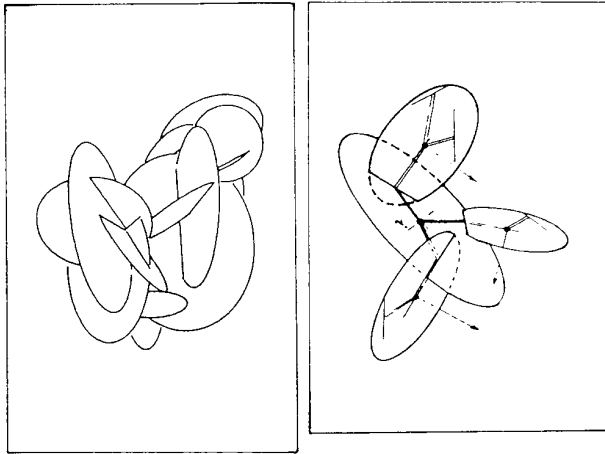

Figure 9. Fracture network simulation and flow modelling (Cacas and Bruel 1989).

orientations and assumed dimensions derived from borehole observations (Fig. 9). These models, too, provide quite good fits to experimental hydraulic data. They show that the fluid has to move from one fracture to another, typically 10-20 times in the 300m between a pair of HDR wells, and that the impedance arises predominantly as a function of the connectivity of the natural system (Ledingham and Lanyon 1989; Cacas and Bruel 1989).

If that is indeed a reflection of reality, it poses a serious problem - and brings me to the question which I said at the beginning that I would pose to you. Available techniques for treating fractures have little effect beyond the first two or three intersections from the well bore (if as far as that). Is there any prospect of being able to control intersections deep within the reservoir, perhaps 150m or more from either well bore? If not, are we justified in continuing with the work?

Faced with these considerations, Tony Batchelor, who was the moving spirit behind the Rosemanowes work (and hence effectively behind the European effort), has recently suggested that we need to adopt a more incremental approach (Batchelor 1989). He now argues that the next step should be taken at a site where the natural fracture system already has the right properties but productivity is limited by recharge problems. He also argues that the first such sites should be on the margins of existing high-enthalpy fields, because it will involve the industry directly, take advantage of existing infrastructures and, perhaps most important of all, provide a more rapid return on capital employed.

This is a very different approach from that which we have been envisaging until now but it does seem to find an echo in the industry. Until recently, the practitioners of classical geothermal systems have tended to be dismissive of HDR research as science fiction. In the last year or so, there has been an interesting shift of attitude among US operators, and quite surprising enthusiasm for continued research. I suspect that this is not unconnected with the recent and belated recognition of water depletion in the Geysers system in California (currently the world's largest geothermal operation with over 2000MWe of installed capacity), which could shut down the operations in as little as 10 years. The HDR approach could give a new lease of life to the field.

Another route may lie in an old idea which has only recently received serious attention. The Rosemanowes team have been looking at the possibility of forming multiple, independent parallel reservoir sections between extended boreholes. Though the engineering would be demanding, this might resolve the impedance problem. It is certainly an aspect that we will need to consider seriously in our future thinking.

Clearly, a great deal of heart-searching will be necessary in the European programme over the next couple of years, and we will need all the assistance that we can get. Any input from people like yourselves, familiar with the characteristics of natural fracture systems but outside the immediate HDR field, will be both invaluable and welcome.

Once again, let me thank you for inviting me to give this Scott Simpson Lecture. The ideas which I have presented are my own, except where I have indicated otherwise; I would not wish my colleagues to take the blame for them. Equally, this paper does not necessarily reflect the views of the European Commission.

References

- Batchelor, A.S. 1989. Hot Dry Rock and its relationship to existing geothermal systems. *Proceedings of the Camborne School of Mines International Conference on HDR Geothermal Energy, 1989*, 13-29.
- Cacas, M. C. and Bruel, D. 1989. Three-dimensional stochastic fracture network model. *Proceedings of the Camborne School of Mines International Conference on HDR Geothermal Energy, 1989*, 309-14.
- DiPippo, R. 1988. International developments in geothermal power production. *Geothermal Resources Council Bulletin*, 17 (5), 8-19.
- Freeston, D. 1990. Direct uses of geothermal energy in 1990. *Geothermal Resources Council Bulletin*, 19 (7), 188-98.
- Genter, A. 1989. Géothermie roches chaudes seches: le granite de Soultz-sous-Forêts. *Doctoral thesis, University of Orléans, 201pp.*
- Geothermal Science and Technology, 1991. Special Issue on the Soultz HDR project 3(1-4).
- Geothermics*, 1987. Special Issue: Proceedings of the 1st EEC/US Workshop on Geothermal Hot Dry Rock Technology, *Geothermics 16 (4)*, 140pp.
- Gérard, A. and Kappelmeyer, O. 1989. European HDR project at Soultz sous-Forêts. *Proceedings of the Camborne School of Mines International Conference on HDR Geothermal Energy, 1989*, 170-9.
- Haenel, R. and Staroste, E. 1988. *Atlas of Geothermal Resources in the European Community, Austria and Switzerland*. EUR 11026, Verlag Th. Schaeffer.
- Harrison, R., Mortimer, N. D. and Smarason, O. B. 1990. *Geothermal Heating: a handbook of engineering economics*. Pergamon, 558pp.
- Huttrer, G. 1990. Geothermal electric power - a 1990 world status update. *Geothermal Resources Council Bulletin*, 19 (7), 175-87.
- Lawton, R. 1986. An analytical model of the HDR reservoir. *Camborne School of Mines Internal Report no. 2B-24*, 14pp.
- Ledingham, P. and Lanyon, G. W. 1989. The controlling influence of natural joint continuity on the creation of HDR systems: experience and modelling. *Proceedings of the 14th Annual Workshop on Geothermal Reservoir Engineering, Stanford, Ca.*
- Schellschmidt, R. and Schultz, R. 1989. Hydrogeothermic studies in the HDR project at Soultz-sous-Forêts. *Proceedings of the Camborne School of Mines International Conference on HDR Geothermal Energy, 1989*, 65-74.